

Convertible trailers

&

Foldable containers

in Global Automotive Logistics

Automotive Logistics

INFORM I Leader in Optimizing Logistics

What makes INFORM special:

Optimization in logistics

More than 600 employees

- global projects
- focus on automotive & container logistics

HQ in Germany; revenue in 2016 €70 million

Many automotive customers like

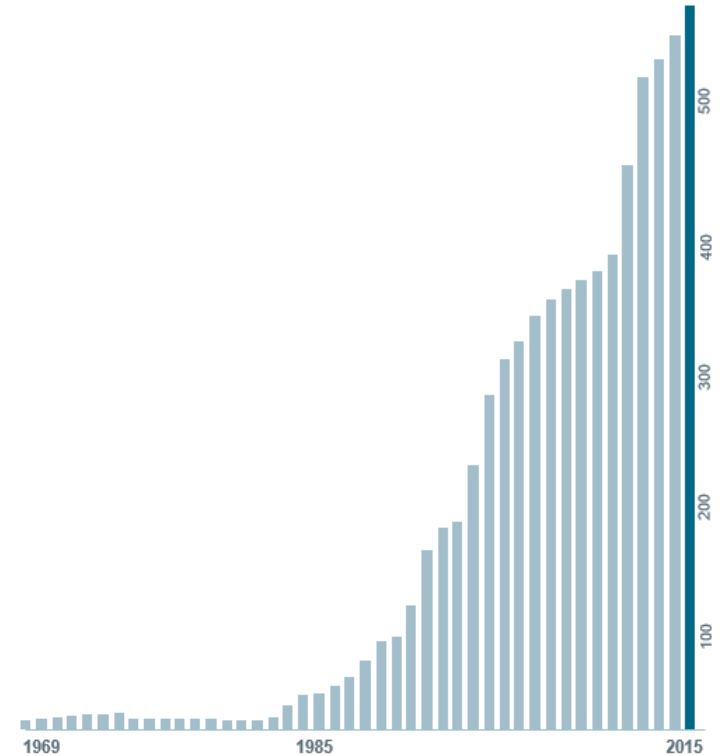

BOSCH

Continental®



VOLKSWAGEN



INFORM Campus in Aachen

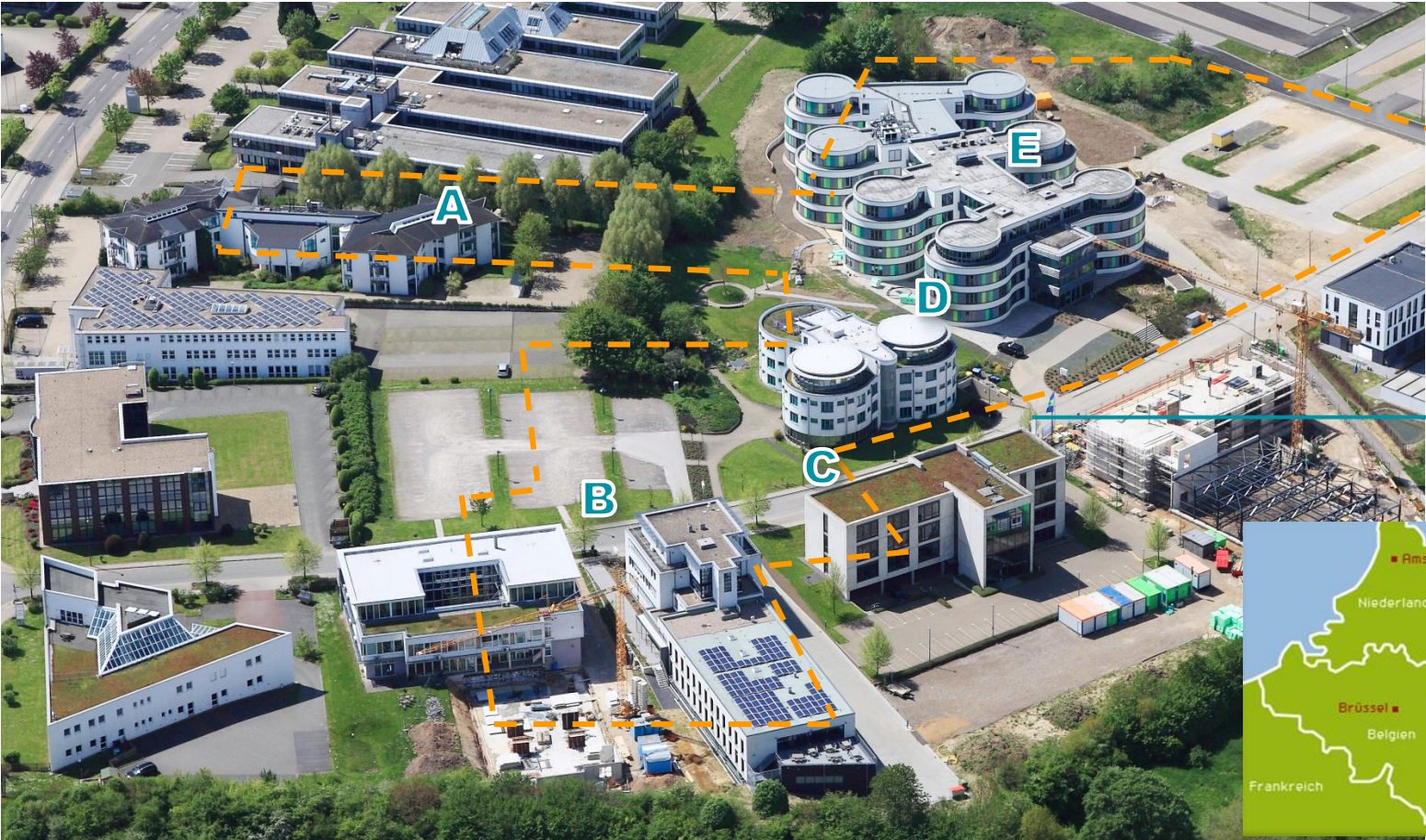

INFORM | Specialist in Optimizing Industry Logistics

Industry Logistics

Mathematical

INFORM

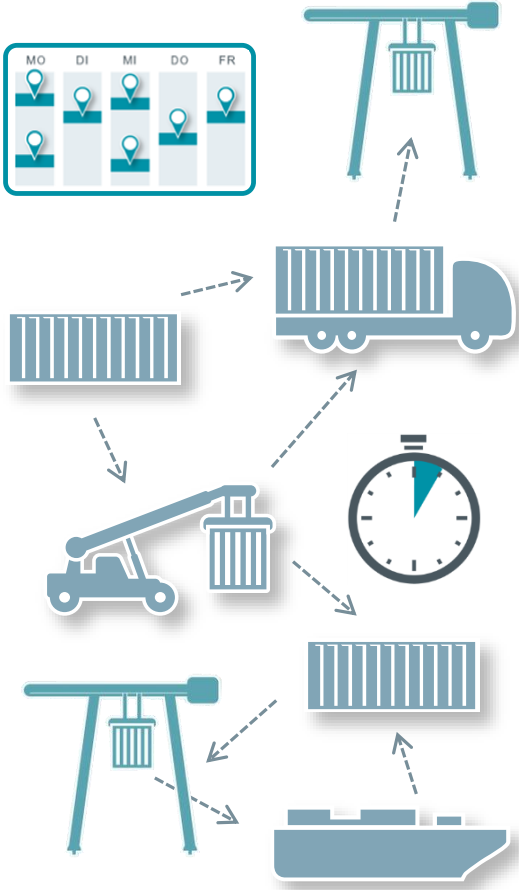
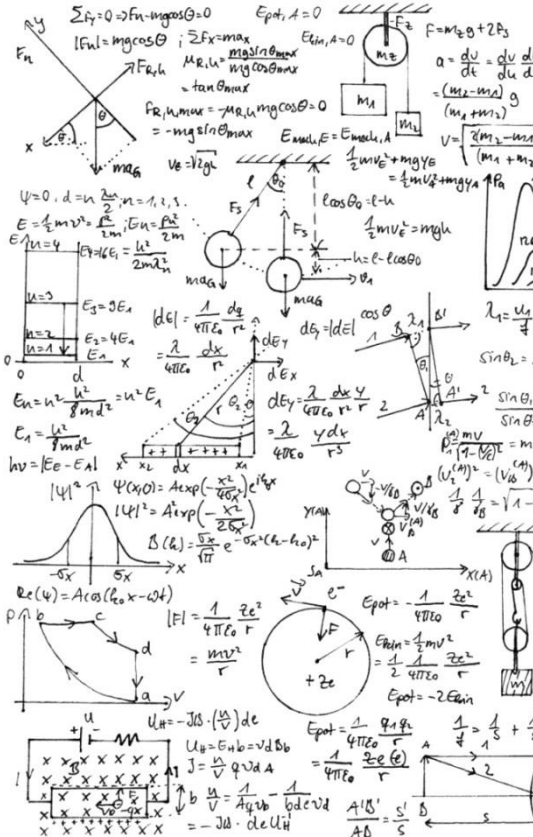
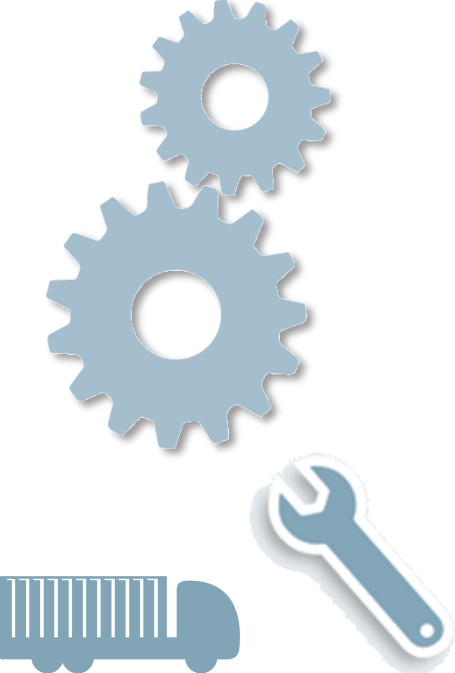

INFORM | Business Units

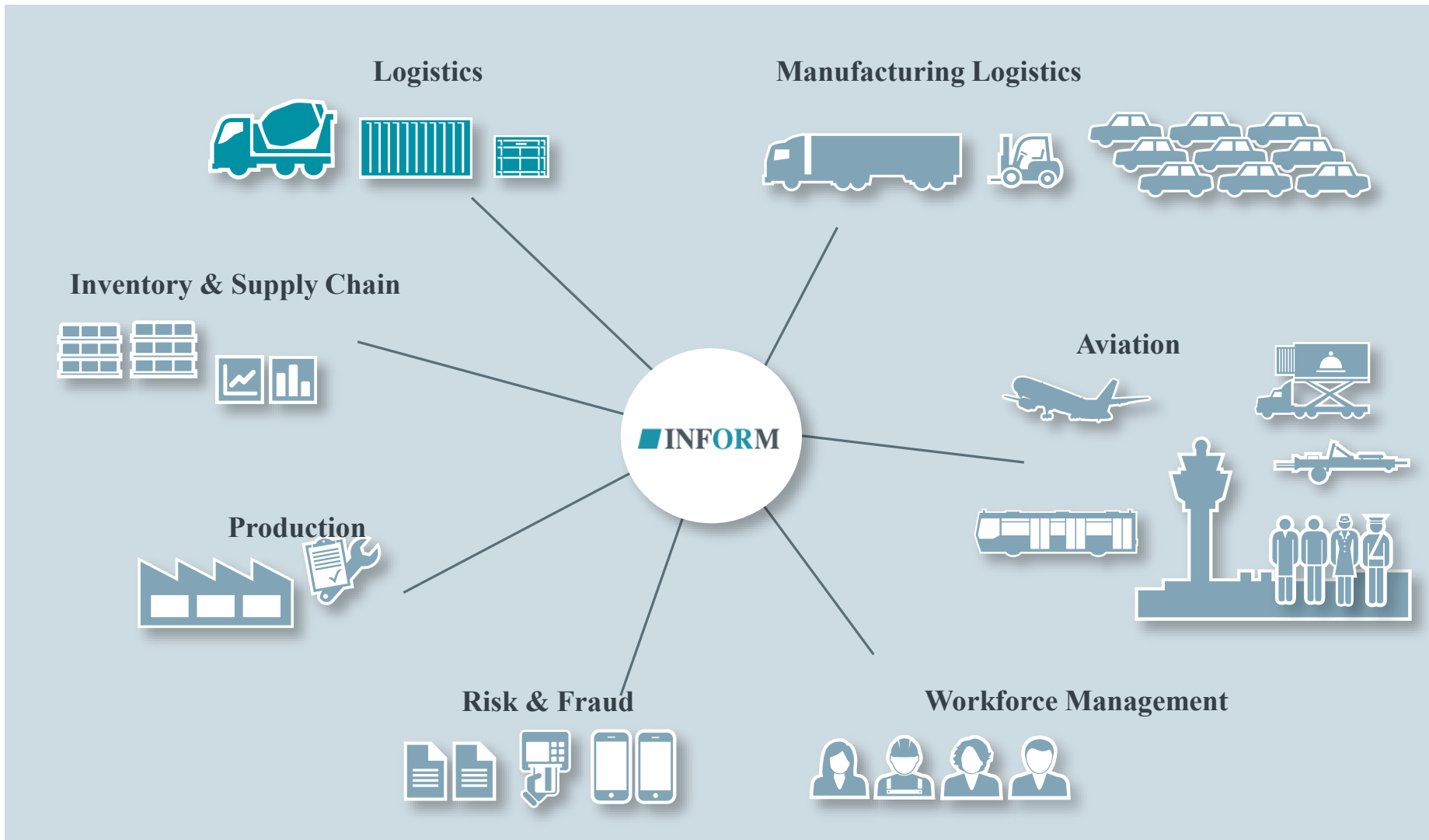

Management Strategies

Unpredictability

- ad-hoc changes
 - volatility
 - time pressure
-
- few changes
 - few disruptions
 - ample planning time

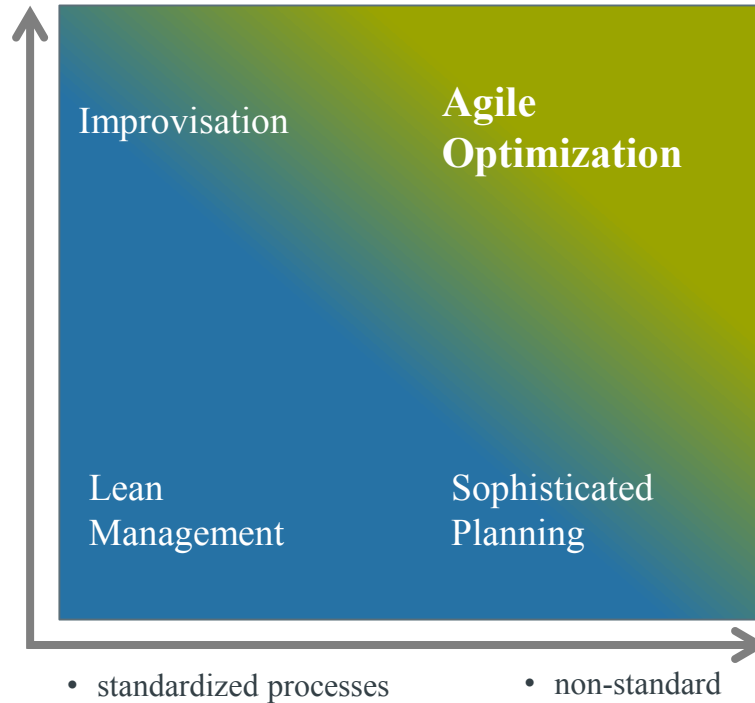

- **smart**
 - **rapid**
 - **interactive**
- mathematical algorithms
 - very short runtimes
 - quickly adaptable

 - human-centered user experience
 - user keeps ultimate control

Complexity

INFORM | Customers worldwide



A world map is centered in the image, with a grid overlay. Surrounding the map are logos of various international companies. The text 'INFORM optimization systems are used by more than 1,000 companies worldwide' is overlaid on the map in a teal color.

INFORM optimization systems are used by more than 1,000 companies worldwide

Logos shown include:

- BDF Beiersdorf, Continental, BOSCH, T, Fraport, BRITISH AIRWAYS, ThyssenKrupp Steel, FUCHS, HHLA
- Linde, ICO, AIRFRANCE, DILLINGER HÜTTE, Emirates, APM TERMINALS, ALSTOM
- FINNAIR, Shell, FROSTA, AIR CANADA, SIEMENS, MAN, AXA, ANDRITZ, HEIDELBERG, MTU, Audi
- BMW Group, interseroh, AIR NEW ZEALAND, Hermes, Alliance 友盟, Prague Airport, KLM, LIEBHERR
- MEYER WERFT, Leica, TURKISH AIRLINES, SAS, Lufthansa, LAFARGE, Volkswagen, VOLKSWAGEN, Hanson, SWISS POST
- bud Budapest Airport, Merck, IPC, H&R, CLAAS, VATTENFALL, CARGOBULL PARTS & SERVICES, GEICO, FUJITSU

Agile Optimization – Digital Fraud Prevention

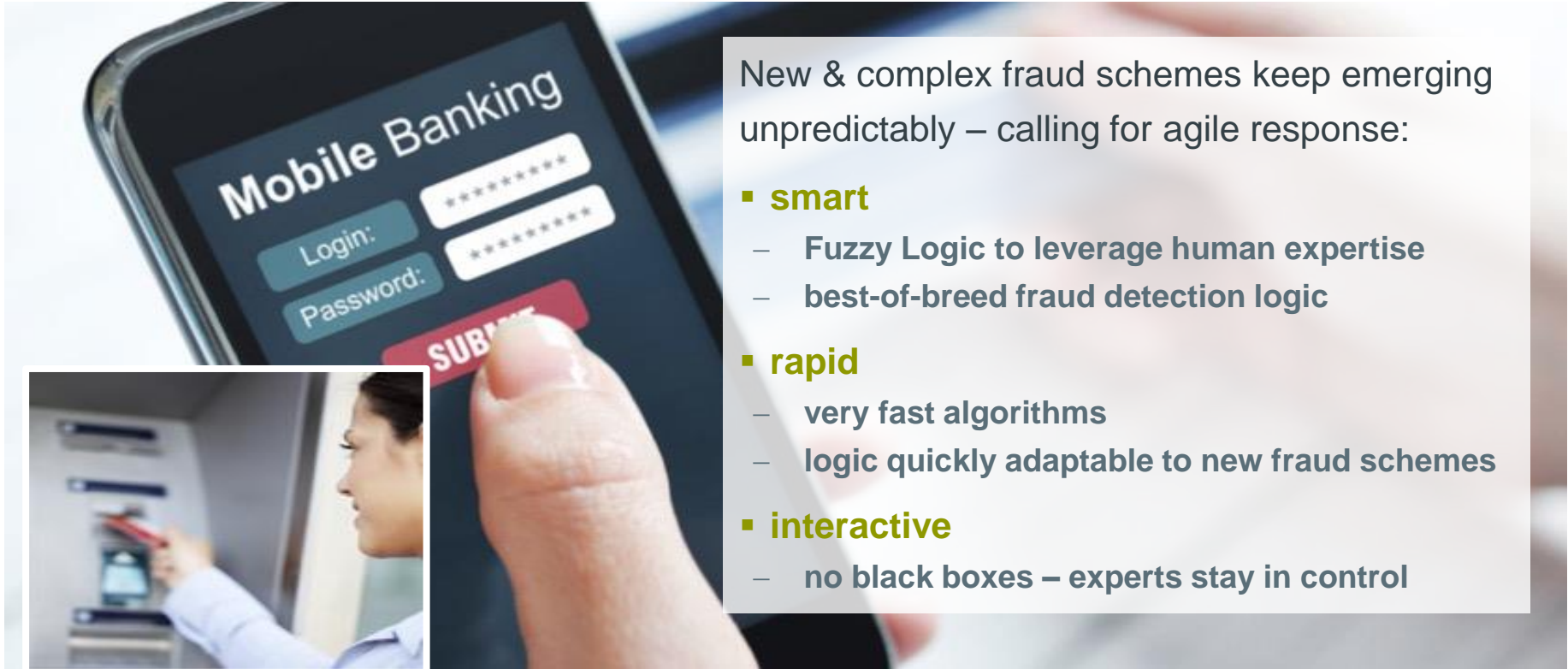

New & complex fraud schemes keep emerging unpredictably – calling for agile response:

- **smart**

- Fuzzy Logic to leverage human expertise
- best-of-breed fraud detection logic

- **rapid**

- very fast algorithms
- logic quickly adaptable to new fraud schemes

- **interactive**

- no black boxes – experts stay in control

RiskShield // Online Banking Fraud in the Netherlands

Total fraud losses in Online Banking has been reduced by **82%**¹ in 2016

- 86%² of Dutch population is using Internet Banking (highest % in EU)
- RiskShield is Dutch market leader in online banking fraud prevention with 85% market share
- Customer are ING, Rabobank, SNS Group, Equens and CCV
- Processing 15 billion payment and card transactions per year

Source: 1] Betaalvereniging Nederland 2] Centraal Bureau voor de Statistiek (CBS)



“Online banking fraud close to zero”

Million of losses reduced to only €148.000 in last 6 months

Internet Banking Fraud (NL)

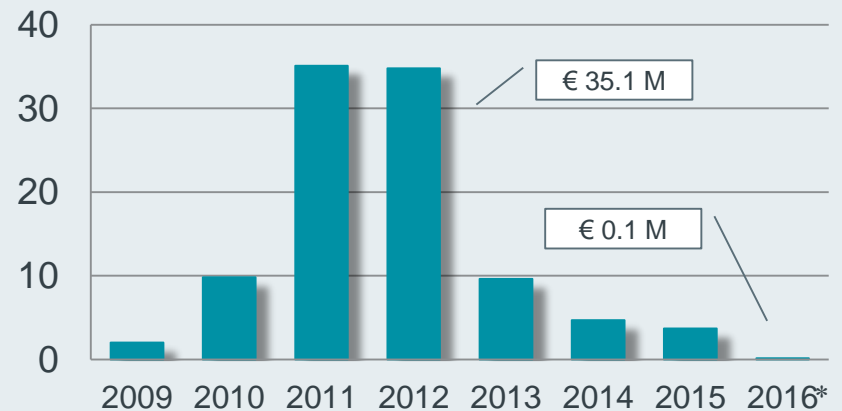

* First 6 months: source Betaalvereniging Nederland

INFORM | Airports & Airlines

Memphis Cargo Hub:

250 planes / 17 million parcels
each night



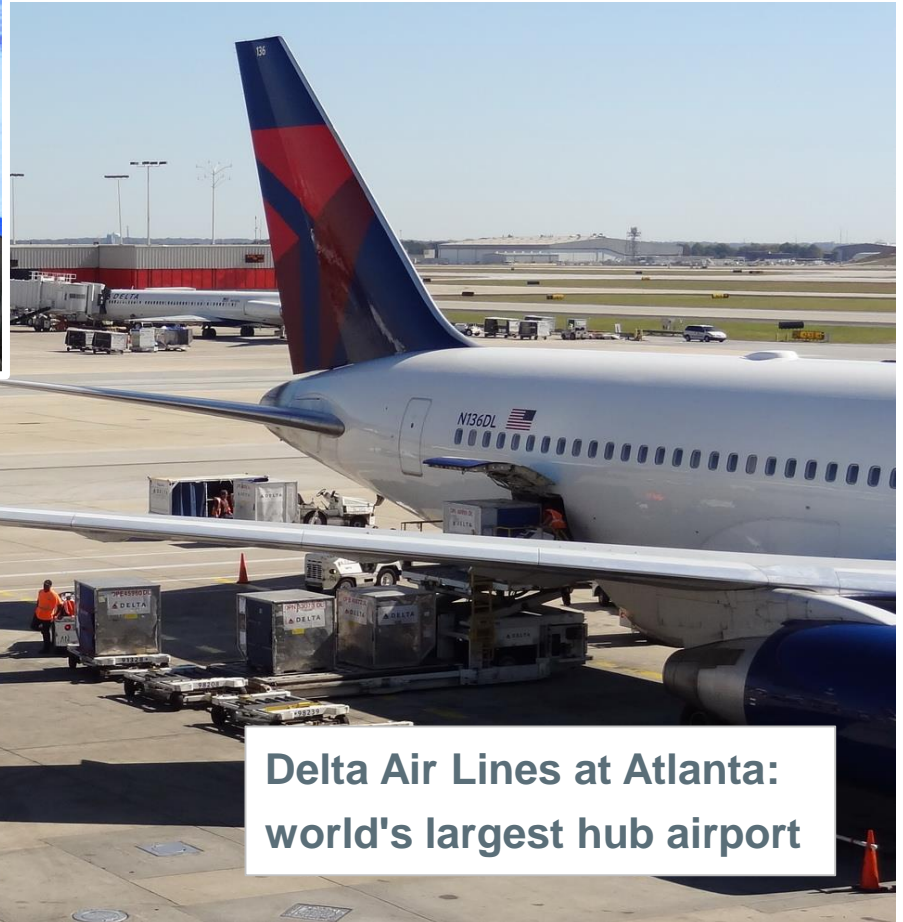
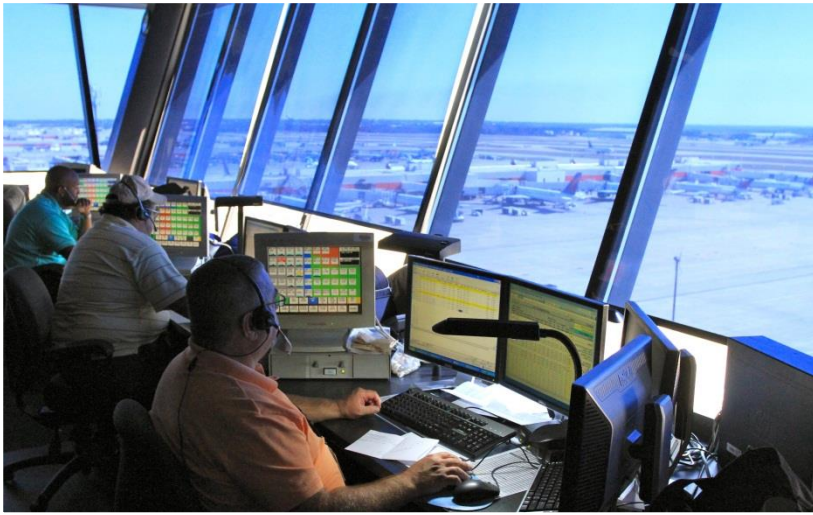

**Delta Air Lines at Atlanta:
world's largest hub airport**

INFORM | Container terminals

Hamburg CTB:

Germany`s largest container terminal



Case Study: APMT (Rotterdam)

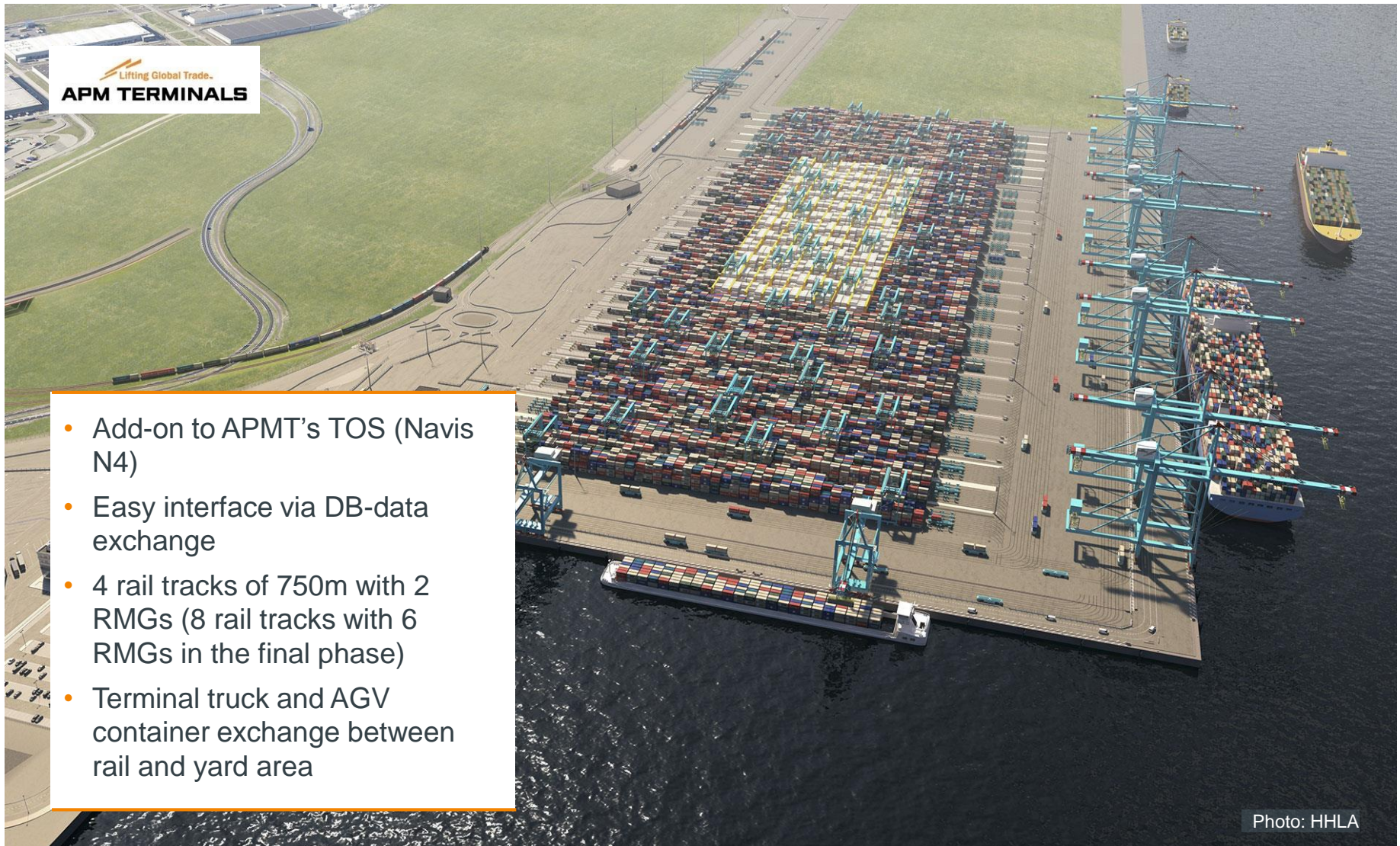

- Add-on to APMT's TOS (Navis N4)
- Easy interface via DB-data exchange
- 4 rail tracks of 750m with 2 RMGs (8 rail tracks with 6 RMGs in the final phase)
- Terminal truck and AGV container exchange between rail and yard area

Photo: HHLA

Retail Supply Chain



Alliance Building Materials, Hong Kong

Ready-mixed Concrete Distribution:

- despite many changes & disruptions
- and massive time pressure!
- efficient on-time deliveries

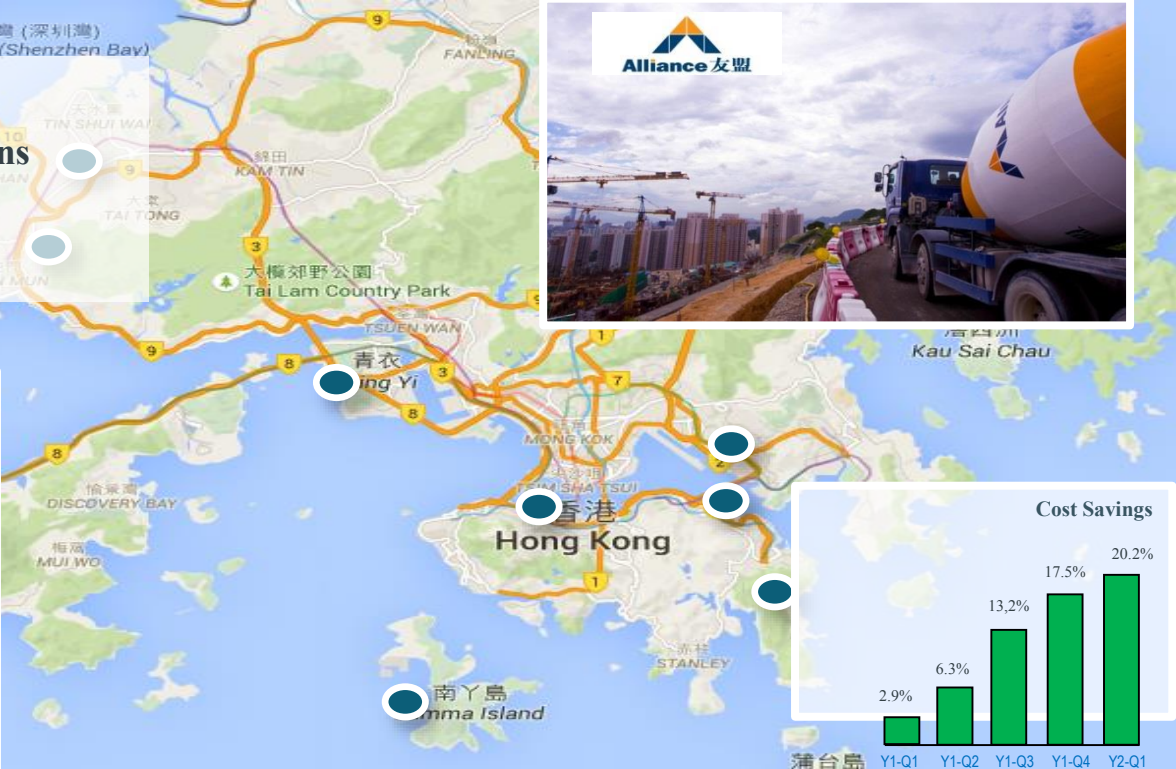

Order No.	Order Date	Order Type	Order Status	Order Description	Order Total	Order Currency
01410	2021-01-14	Standard	Delivered	Ready-mixed concrete	1,200,000.00	HKD
01427	2021-01-15	Standard	Delivered	Ready-mixed concrete	1,500,000.00	HKD
01431	2021-01-16	Standard	Delivered	Ready-mixed concrete	1,800,000.00	HKD
01437	2021-01-17	Standard	Delivered	Ready-mixed concrete	1,600,000.00	HKD
01438	2021-01-18	Standard	Delivered	Ready-mixed concrete	1,400,000.00	HKD
01447	2021-01-19	Standard	Delivered	Ready-mixed concrete	1,700,000.00	HKD
01447	2021-01-20	Standard	Delivered	Ready-mixed concrete	1,900,000.00	HKD
01447	2021-01-21	Standard	Delivered	Ready-mixed concrete	1,500,000.00	HKD
01447	2021-01-22	Standard	Delivered	Ready-mixed concrete	1,300,000.00	HKD
01447	2021-01-23	Standard	Delivered	Ready-mixed concrete	1,100,000.00	HKD
01447	2021-01-24	Standard	Delivered	Ready-mixed concrete	900,000.00	HKD
01447	2021-01-25	Standard	Delivered	Ready-mixed concrete	700,000.00	HKD
01447	2021-01-26	Standard	Delivered	Ready-mixed concrete	500,000.00	HKD
01447	2021-01-27	Standard	Delivered	Ready-mixed concrete	300,000.00	HKD
01447	2021-01-28	Standard	Delivered	Ready-mixed concrete	100,000.00	HKD

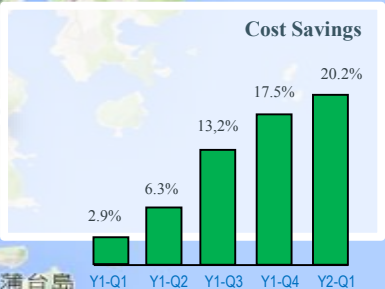

Global Spare Parts Distribution

Supply Chain for Automotive Spare Parts:

- challenged by highly volatile demands
- agile demand & supply chain planning
- optimizing stock & customer service levels

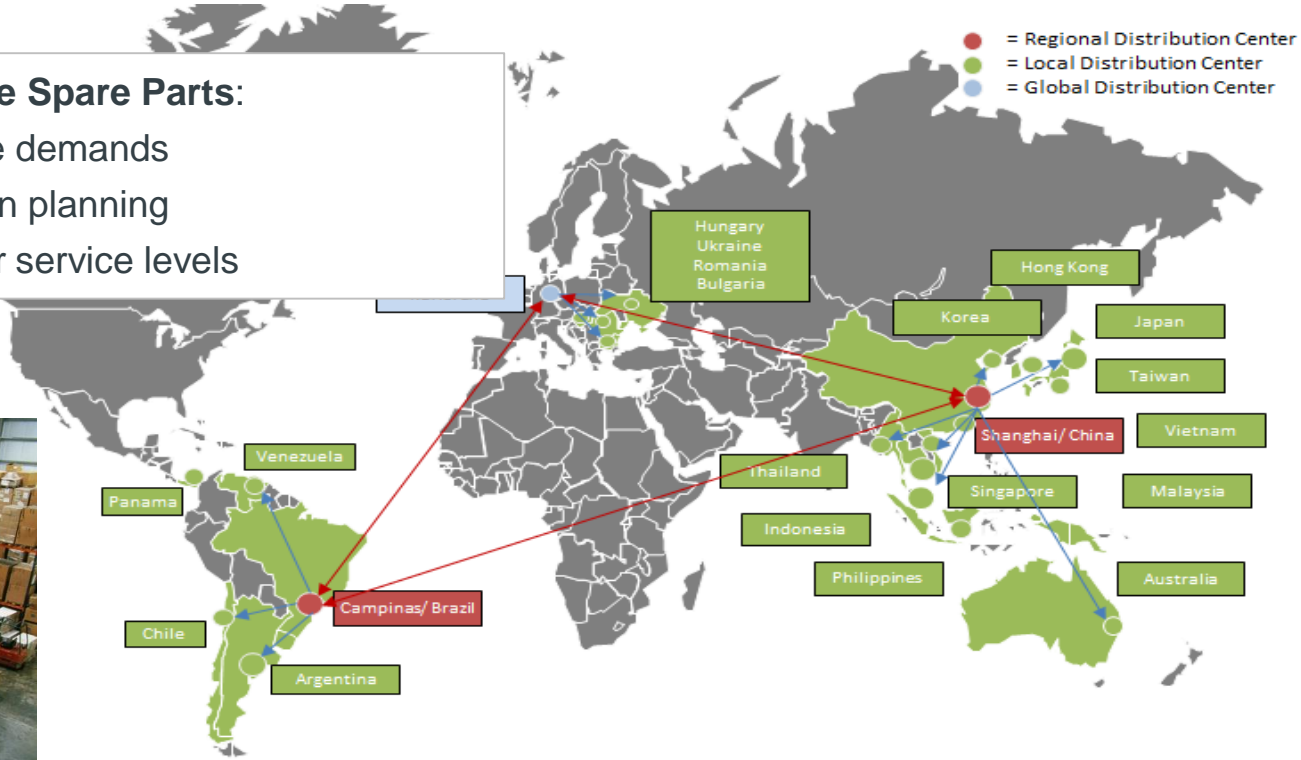

Audi Ingolstadt

Factory Logistics:

- agile optimization of inbound trucks
- real-time dispatch of in-plant forklifts, etc
- for 100% reliable production supplies

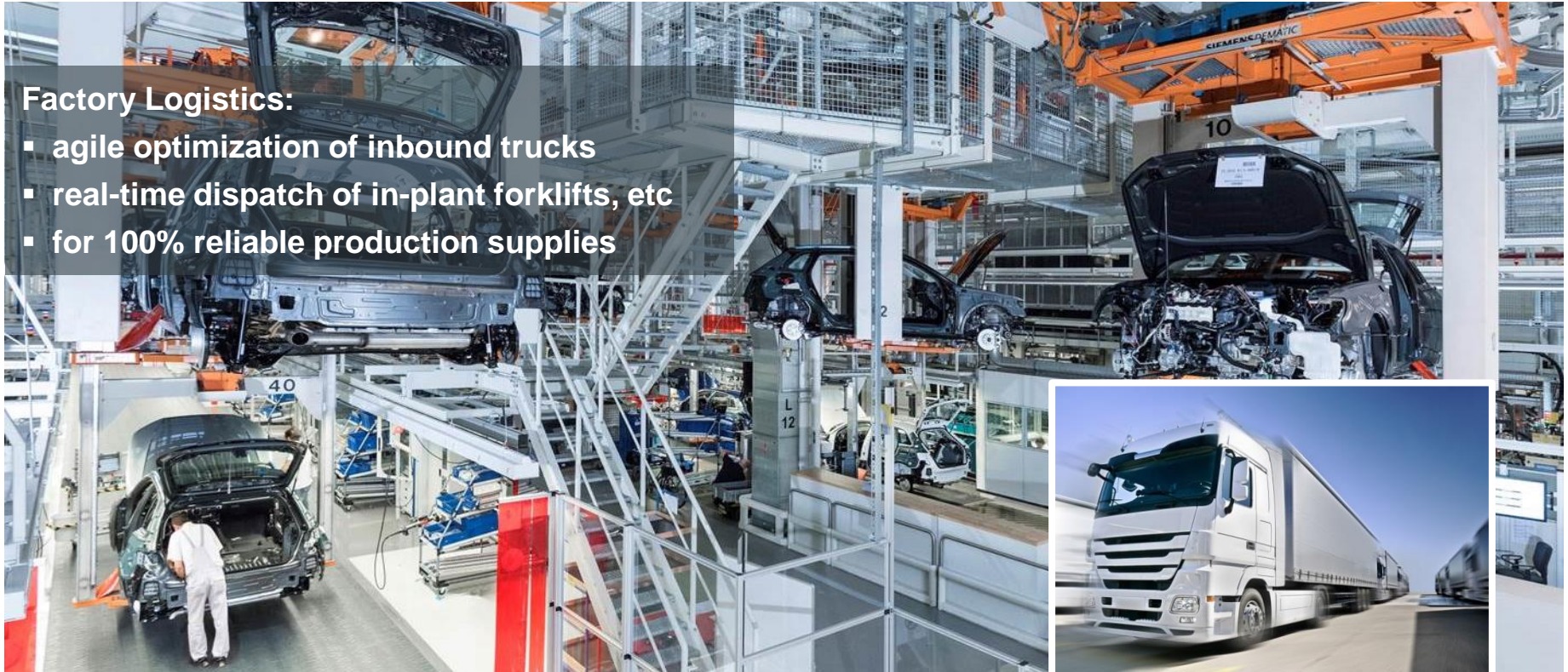

Volkswagen Mexico

VW Mexico, Yard and Transport Optimization

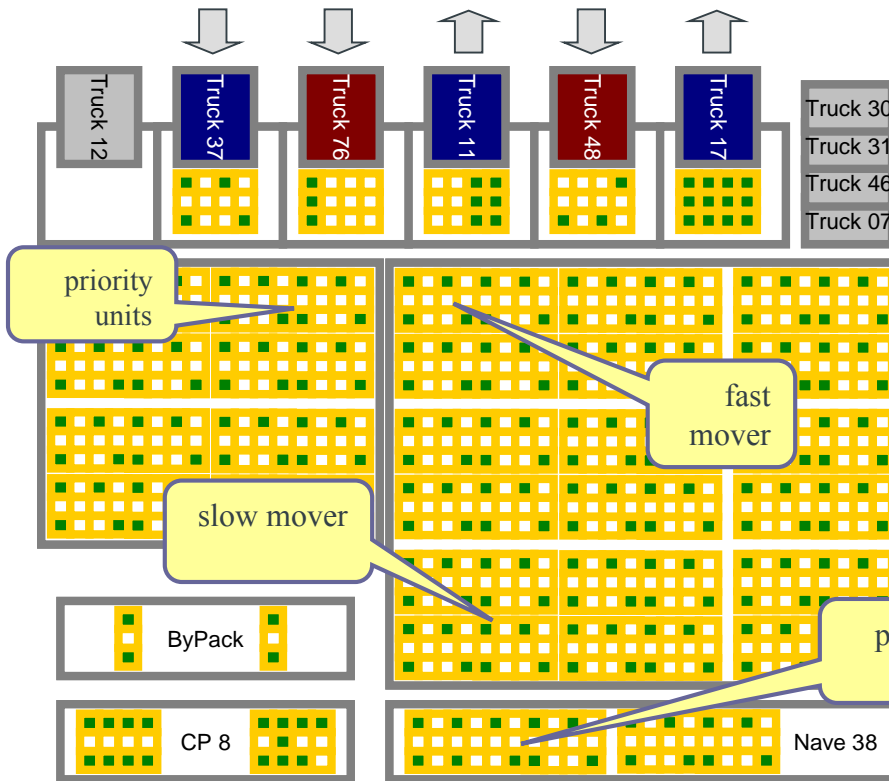

INFORM | Ford Europe and Asia



Northamerica

Europe + Asia

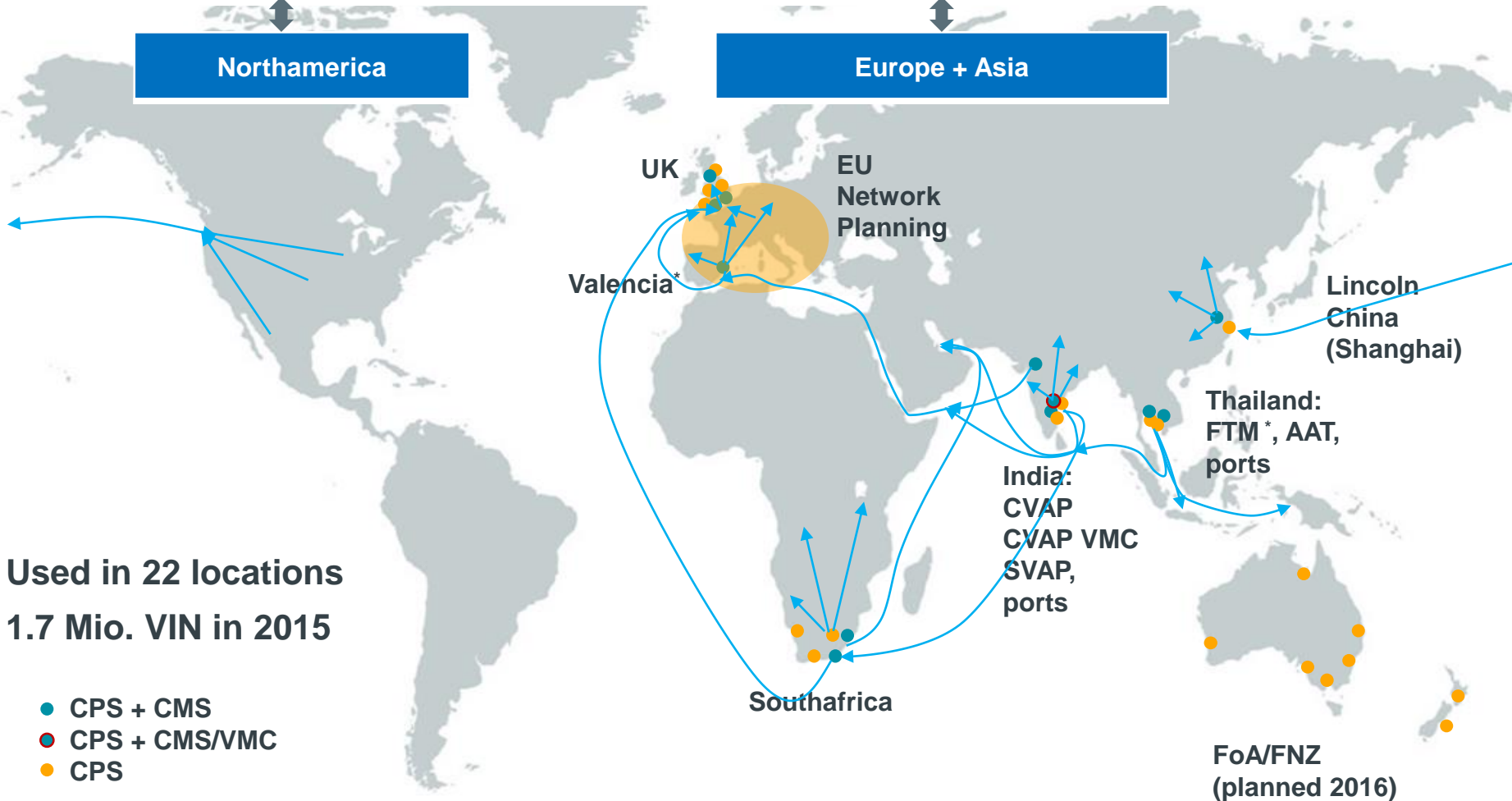

Used in 22 locations
1.7 Mio. VIN in 2015

- CPS + CMS
- CPS + CMS/VMC
- CPS

INFORM | largest car terminal in world: Zeebrugge

2.5 million cars in 2015 in Zeebrugge port: largest car terminal in world

40% growth since 2012

ICO is leading party: 1.7 million in 2015 in Zeebrugge



INTERNATIONAL CAR OPERATORS



Challenges in logistics today....

Trucks in vehicle logistics are 40-50% empty in many places in the world.....

Containers are 40-50% empty in many places in the world.....

How can we solve this problem?

TURN AND



~~BURN~~
EARN!
MAKE BACKHAULS PAY

Convertible trailers | Further optimization possibilities



CLIC Outbound flows in Europe



CLIC All OEM imbalances in Europe over all brands

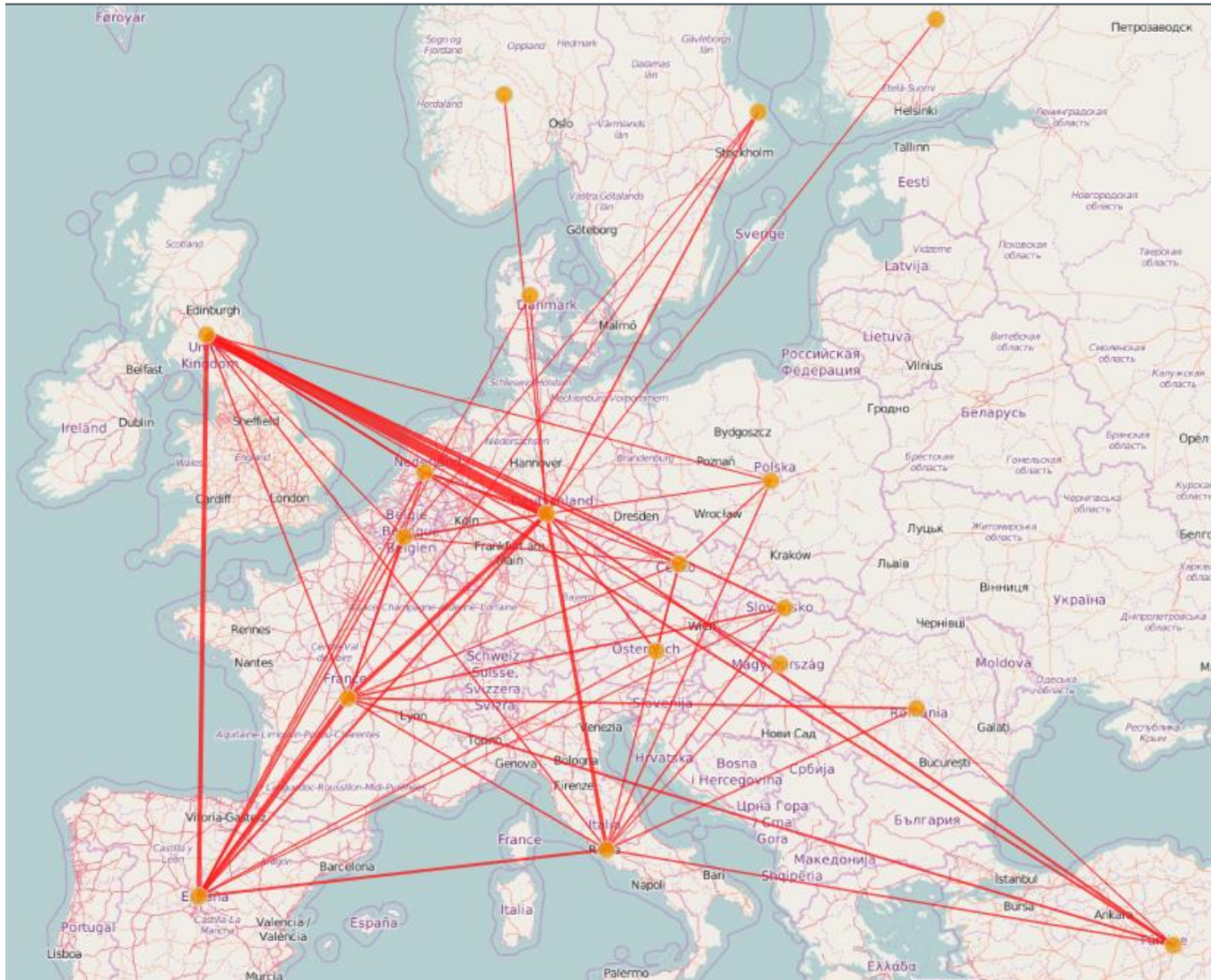

CLIC Inbound flows in Europe (engines and transmissions)

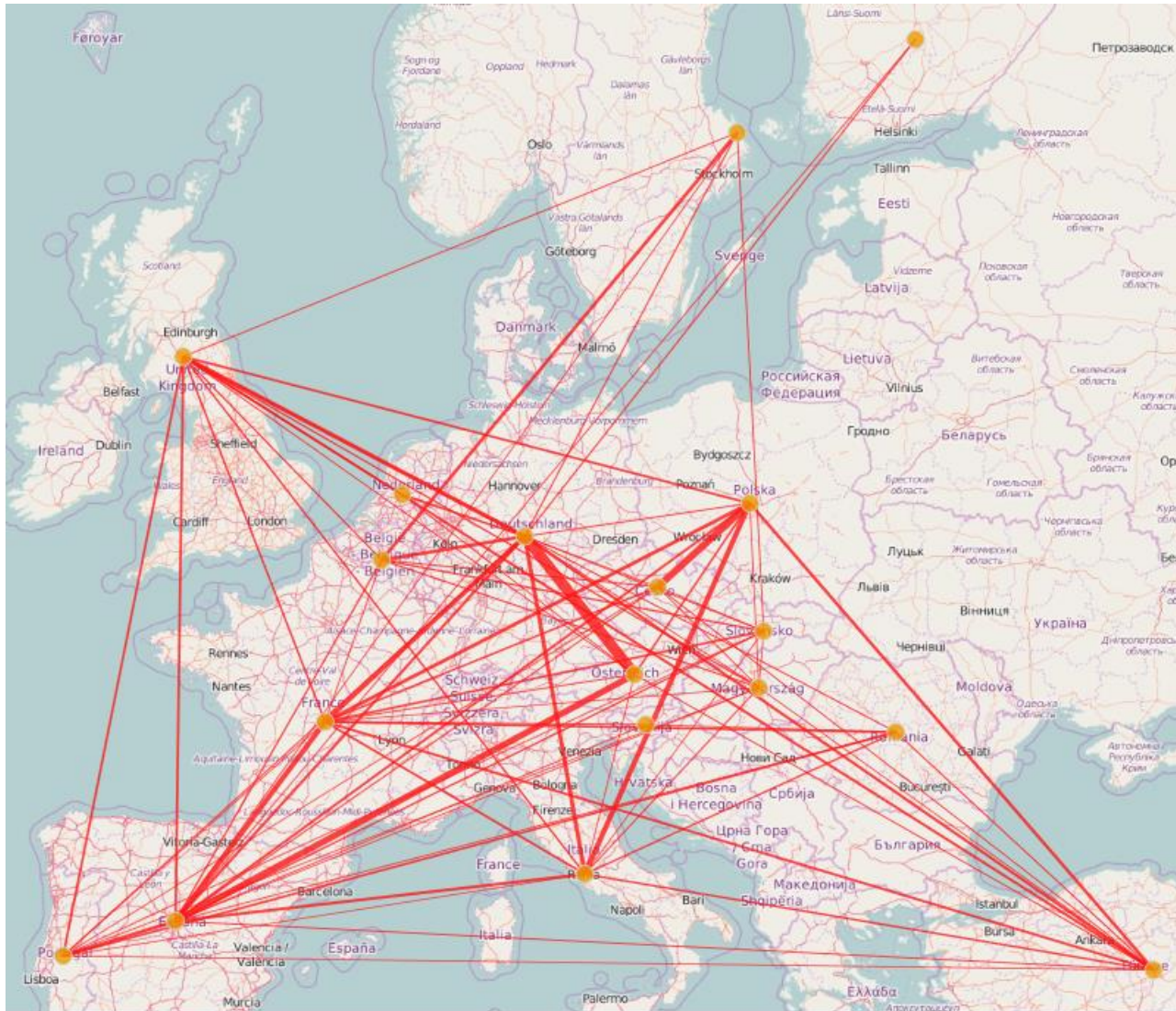

CLIC | Where can convertible trailer help to reduce empty driving?

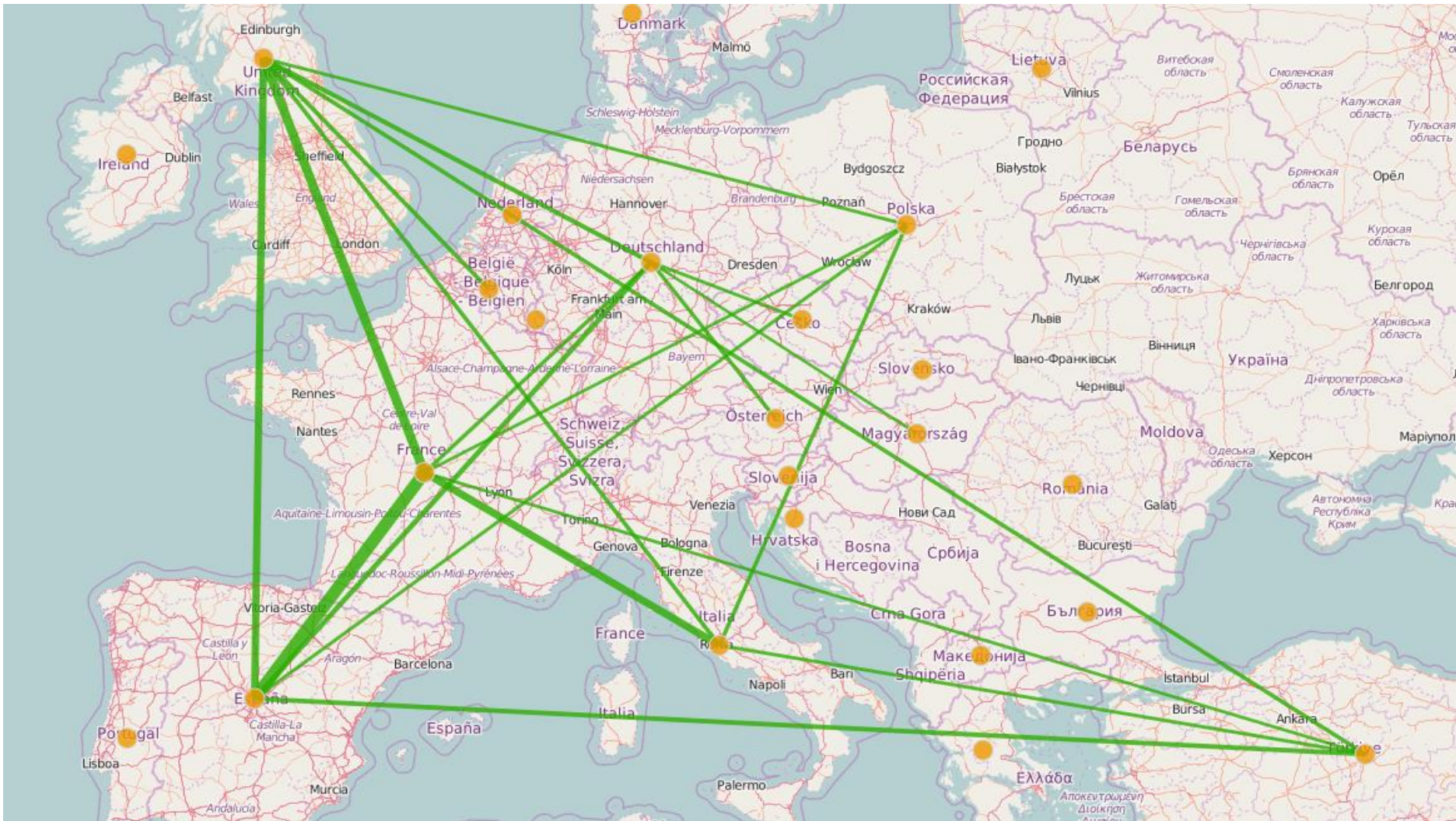

New technologies | **Hardware**

Stop with empty trucks in finished vehicle logistics



Stop with transporting empty containers:
Use foldable containers



Convertible and foldable concept

TURN AND



~~BURN~~
EARN!
MAKE BACKHAULS PAY

Convertible trailers | Further optimization possibilities



Stop with empty trucks in finished vehicle logistics



Stop with transporting empty containers:
Use foldable containers



Convertible Trailer+Folded Container | More than 30% potential?

Trip 1: trailer filled with cars from factory to region A

Trip 2: trailer filled with filled container from region A to factory

Trip 3: trailer filled with cars from factory to region A

Trip 4: trailer filled with filled container from region A to factory

Trip 5: trailer filled with cars from factory to region A

Trip 6: trailer filled with filled container from region A to factory

Trip 7: trailer filled with cars from factory to region A

Trip 8: trailer filled with filled container from region A to factory

Trip 9: trailer filled with 4 folded empty containers from factory to region A

Trip 10: trailer filled with filled container from region A to factory

Trip 11: trailer filled with cars from factory to region A

Trip 12: trailer filled with filled container from region A to factory

Trip 13: trailer filled with cars from factory to region A

Trip 14: trailer filled with filled container from region A to factory

Trip 15: trailer filled with cars from factory to region A

Trip 16: trailer filled with filled container from region A to factory

Trip 17: trailer filled with 4 folded empty containers from factory to region A

Trip 18: trailer filled with filled container from region A to factory

Summary:

Traditional

7 trips with cars+7 times empty back

9 full container trips+9 times back with empty container

Convertible trailer+ foldable container

7 trips with cars+7 trips back with filled containers

2 trips with folded empty containers+2 trips back with filled container

32 trips needed

versus

18 trips needed

44% saving on kilometres!

More information?

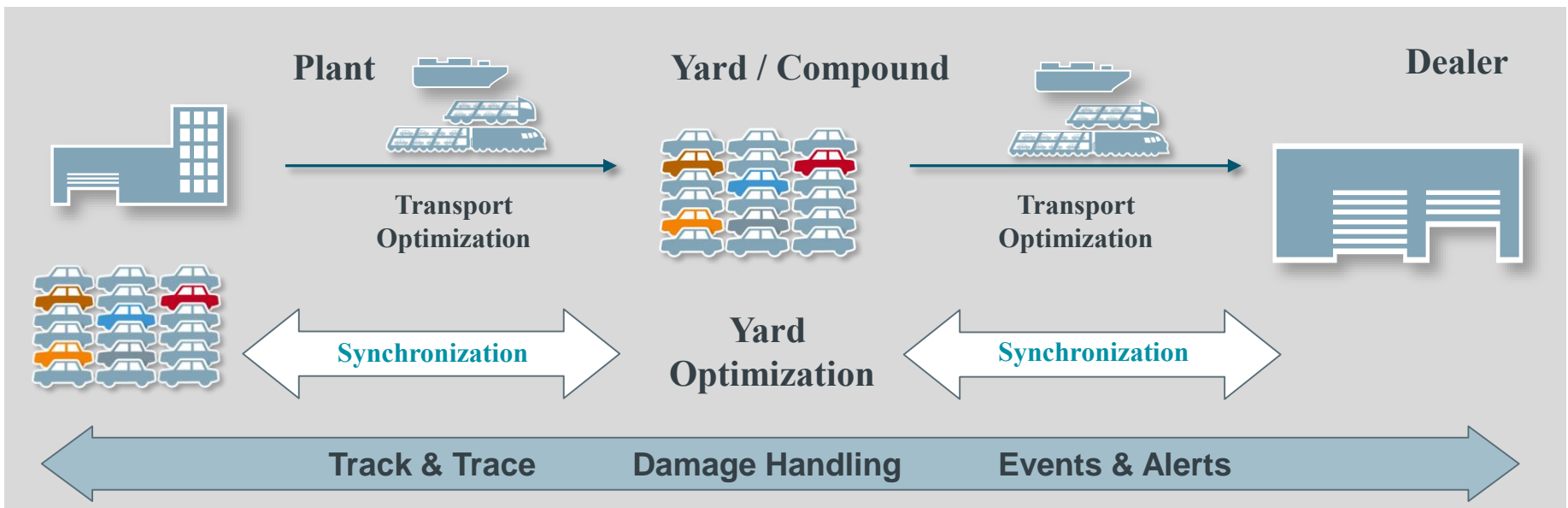

Ruud Vossebeld

Director Business Development

Email ruud.vossebeld@inform-software.com

Phone +31 6 54 677680 or +49 2408 9456 0

Internet www.inform-software.com



Thank you!